

**( Other Products Available From Apollo )**

*Smart Move® Rotators • Right Arm® • Gel Miser  
Stainless Steel Gobos • Glass Gobos • Gel Filters  
Dichroics • Tape • Pattern Holders • Donuts  
And Much More!*



**Apollo Design Technology**  
4130 Fourier Drive Fort Wayne, IN 46818 USA  
Phone: +01.260.497.9191  
Fax: +01.260.497.9192  
[www.apollodesign.net](http://www.apollodesign.net)

04/21/09

SMART COLOR®

**SCROLLER OPERATING MANUAL**





---

## ( Limited Warranty )

Items are covered for defects in materials and workmanship for one year, including repair parts and repair labor on defective item, from date of Apollo invoice. The warranty covers freight for 30 days after initial purchase. Apollo does not cover any other loss resulting from product failure.

Products being returned for warranty repair must display the original serial number sticker. Removal of the serial number sticker voids the product's limited warranty.

## ( Standard Smart Color® Features )

- State-of-the-art digital circuitry with rotary DMX addressing
- Automatic scrolling function – no console needed
- Various length gel string scrolling capability (2-16 colors)
- Control via USITT DMX512 (1990) protocol for individual addressing and easy grouping of multiple units
- Multi-speed internal cooling fan
- Apollo Gel Shield – eliminates IR transmission
- Two diagnostic LED indicators for power and data status
- XLR 4-pin connectors supply power and control signal
- Easily accessible reset/test button
- One standard mounting plate for your choice of fixture
- Durable, lightweight aluminum w/matte black powder coat finish

## ( Other Smart Color® Accessories )

- Power supplies for up to 18 scrollers
- Universal Mounting Plate for fixtures with 6.25" - 10" color frames
- 4-pin accessory cables for daisy-chaining scrollers
- 5-pin DMX512 cables for data transmission from console
- Stock theater, rock 'n roll and custom gel strings
- 4-pin data terminator
- Apollo PerfGel™ for custom gel string use
- Apollo black stage foil

---

## ( Product Overview )

The Smart Color® scroller from Apollo is designed to be among the most reliable color scrollers available today. By using state-of-the-art digital circuitry and lightweight aluminum alloy, the Smart Color® scroller allows projection of two to sixteen gel colors affordably.

The Smart Color® is designed to give years of trouble-free use, providing it is used in accordance with the instructions detailed in this manual. If you should experience any problems that fall outside of the scope of this manual, contact the selling dealer for further details.

If the selling dealer is unable to satisfy your servicing needs, contact Apollo directly for technical support. The contact information is listed on the back cover of this manual.

---

## ( Product Description )

The Smart Color® operates using USITT DMX512 (1990) protocol, which enables individual addressing of each unit and allows for easy grouping of multiple units. The units are individually addressed by setting the three rotary binary switches to the desired DMX address. You may set the scrollers with the same DMX address when the group is to perform the exact same color changes on the same cue.

The Smart Color® receives power and control signal through an XLR 4-pin input connector. The XLR 4-pin output may then be used to connect (daisy-chain) other units to the same line. Each daisy-chained group of scrollers must be terminated by plugging the output from the last scroller in the chain to its corresponding return connection on the Power Supply (PSU). This allows maximum performance of the 4-pin system. The System Diagram is located on page 5.

**Note:** *The quantity of Smart Color® scrollers and maximum cable length per distribution line is dependent upon the size of the PSU and the total amperage draw of the units connected (see page 3 and 4 for full details).*

Each Smart Color® scroller is equipped with two diagnostic LED indicators found on the front cover of the unit showing Power and DMX signal (page 6) and a variable speed internal cooling fan (page 7).

## ( PSU Options )

The Smart Color® scroller is compatible with the following 24V DC power supplies:

- Smart Power™
- Color-Q™ PSU 02-4
- Wybron Forerunner™
- Spectra-Q™
- Chroma-Q™
- Rainbow™

**( DO NOT PLUG SMART COLOR® INTO THE WYBRON COLORAM POWER SUPPLY! )**

Because of reversed power pin designation; using the Wybron Coloram PSU will cause serious damage to the Smart Color® electronics.

The Apollo PSU is available in 4 sizes:

### **PSU 75W**

1.88A-75 Watt max, 100-240 VAC input, 50-60Hz

**Powers up to 2 Smart Color® Scrollers**

### **PSU 200W**

6.25A-150 Watt max, 85-260 VAC input, 50-60Hz

**Powers up to 6 Smart Color® Scrollers**

### **PSU 400W**

10.4A-250 Watt max, 115 or 230 VAC input, 24 volt output, 50-60 Hz

**Powers up to 12 Smart Color® Scrollers**

### **PSU 600W**

16.6A-400 Watt max, 115 or 230 VAC input, 24 volt output, 50-60 Hz

**Powers up to 18 Smart Color® Scrollers**

Apollo PSU models have a universal power input cord which can be interchanged with a locally available power cord, matching the available power outlet. This applies to sales outside North America.

## ( Troubleshooting )

All troubleshooting procedures should begin with an LED and cable connection check. DMX cables are often the cause of scroller problems.

Symptom	Possible Cause	Solution
Scrollers have no power. All RED LED's out.	24V DC power supply is not plugged in.	Check if PSU main power LED is on. Plug PSU into non-dimmed circuit.
Single scroller power indicator is off (RED LED).	4-pin XLR cable has a broken connection.	Replace 4-pin XLR cable with a known working piece of cable. Swap between units to verify condition of suspected cable.
One or more scrollers are resetting when moving at high speed.	Voltage has dropped below acceptable level.	Check that the return cable has been installed. Check that maximum cable length has not been exceeded or too many scrollers on circuit.
DMX indicators (GREEN LED) on all scrollers are off.	No DMX is present at the PSU.	Check that the DMX cable is properly connected to DMX input on the PSU. Check that the DMX indicator light, located on the PSU, is on.
DMX indicators (GREEN LED) on one group of scrollers are off.	One output of PSU has failed. Faulty XLR 4-pin cable at PSU output.	Test the condition of cables with known working cables. Replace as necessary.
Rattling sound when gel string advances.	Loose thumbscrews on top of fixture.	Tighten thumbscrews with fingers until snug.
DMX indicator (GREEN LED) flashes slowly.	Motor or gel string is jammed.	Inspect scroller for roller obstruction or disconnected gel roller. Replace onto roller bearing. Remove debris.
DMX indicator (GREEN LED) flashes quickly.	Broken gel string.	Inspect gel string rollers. Tape string back onto roller or frames back together with gel tape.
Gel string is noisy, wrinkled or has a hole in center of frame.	Lamp was powered before scroller fan. LOW fan speed has been set.	Always power scroller before lamp. Add Apollo Gel Shield to scroller. Set fan speed at HIGH. Replace gel frame or string.
Gel string and rollers stop when reset.	String tension has become too loose between rollers.	Power down the scrollers at mains or XLR connector, and then re-apply power.

**( 4-Pin Data Cable Specifications )**

<b>Physical Specifications</b>	
<b>Conductor</b>	<ul style="list-style-type: none"> <li>• Data pair; 22 AWG tinned, annealed copper stranded 19/34</li> <li>• Power: 14 AWG bare, annealed copper stranded 41/30</li> </ul>
<b>Insulation</b>	<p><b>Data pair: color coded high density polyethylene, Red/Green</b></p> <ul style="list-style-type: none"> <li>• Nominal Wall: 0.0095"</li> <li>• Minimum Wall: 0.007"</li> </ul> <p><b>Power: color coded, PVC 80°C, 300 volt black &amp; white</b></p> <ul style="list-style-type: none"> <li>• Nominal Wall: 0.015"</li> <li>• Minimum Wall: 0.012"</li> </ul>
<b>Shield</b>	<b>Aluminum/mylar around 22 AWG pair, aluminum side in, 100% coverage</b>
<b>Drain</b>	<b>24 AWG tinned, annealed stranded 7/32</b>
<b>Jacket</b>	<ul style="list-style-type: none"> <li>• Black PVC</li> <li>• Nominal Wall: 0.035"</li> <li>• Elongation: 100% minimum</li> <li>• Tensile: 2,000 PSI minimum</li> </ul>
<b>O.D. Weight/m ft.</b>	<b>Nominal O.D.: 0.290" Weight: 60 lbs. per 1,000 ft.</b>

<b>Environmental Specifications</b>	
<b>Operating Temperatures</b>	<b>Plus 80°C, Minus 20°C</b>
<b>Conductivity</b>	<b>15.5 Ohm (max.) per 1,000 ft. @ 25°C</b>
<b>Impedence</b>	<b>Data pair: 60 Ohms calculated</b>
<b>Capacitance</b>	<ul style="list-style-type: none"> <li>• Data pair: 27 pf./ft. nom. cond. to cond.</li> <li>• 51 pf./ft. nom</li> </ul>

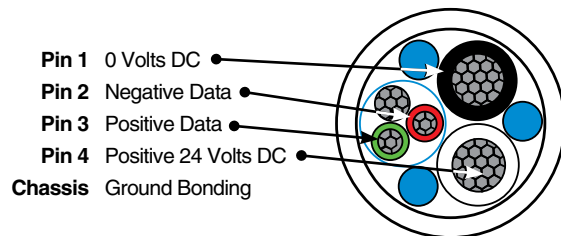

**( Power Supply Use )**

The basic purpose of the PSU is to combine the data control signal and 24VDC power into individual lines. There are separate circuit outputs for distribution on each PSU, each capable of supplying power and data for Apollo Smart Color® scrollers and Apollo Smart Move® rotators.

The maximum total cable length for each output circuit is 200 feet/60m **and requires a 4-pin return line to achieve maximum performance.** Be sure to plug the PSU into a NON-DIMMED circuit.

For the **PSU 200W, 400W, and 600W**, all outputs are independent of one another and each line has its own return. The purpose of the return line is to maintain a constant voltage level across all units on each line, to reduce line loss and to provide data signal termination at the PSU. The 4-pin return line is required for maximum performance.

The **PSU 200W, 400W, and 600W** provides opto-isolation between the incoming DMX and the DMX distributed to the scroller outputs. A separate line driver IC buffers each DMX output.

**Each Apollo PSU 200W, 400W, and 600W is equipped with the following:**

- 1) XLR 5-pin male and female ports as DMX input and thru ports.
- 2) Two XLR male 4 pin output ports for power and DMX.
- 3) Two XLR female 4 pin output ports for power and DMX.
- 4) Main power indicator (Red LED).
- 5) 6 ft. AC Edison power cord.

**Each Apollo PSU 75W produces 1.88A and is equipped with the following:**

- 1) XLR 5-pin male as DMX input port.
- 2) One XLR female 4-pin output port for power and DMX.
- 3) Main power indicator (Green LED).
- 4) 6 ft. AC Edison Power cord.

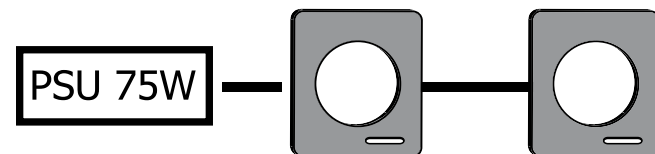

## ( Control and Power Cables )

Apollo Design Technology 4-pin data cable (accessory cable) is recommended for use with the Smart Color® system. Other high quality shielded cables are also acceptable. Inspect cables before use.

The Smart Color® uses an XLR 4-pin cable system for power and data transfer. Pins 1 and 4 serve as 24VDC power. Pins 2 and 3 are used to carry USITT 1990 DMX512 control protocol.

**Note:** It is very important to ensure that the drain wire from the cable shield is connected to **both** connector cases, should you use cable other than the Apollo brand.

**Note:** When assembling XLR 4-pin cables, heat shrink tubing should be used over the soldered connection for each pin to prevent short circuits.

**Note:** Damage will occur if power connections short-circuit to control protocol or ground shield connections.

The pins are wired one to one, in the following format:

Pin	Function
1	0V DC
2	Control Data Minus
3	Control Data Plus
4	Plus 24V DC
Chassies	Ground Bonding

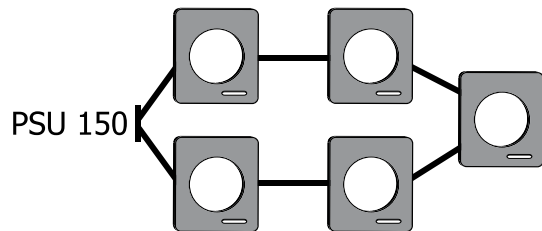

**Note:** Total cable length per circuit must not exceed 200 feet/60m. The use of a 4-pin return line must be used to minimize voltage drop and allow maximum performance. Route the 4-pin return cable from the last scroller back to the PSU 200W, 400W or 600W to maintain line voltage across the system, and to terminate the data signal.

## ( Power Supply 75 Specifications )

**Dimensions:** 7" (H) x 3" (W) x 1" (D)  
177.8mm (H) x 76.2mm (W) x 25.4mm (D)

**Weight:** 1.5 lbs. / 0.68 kg.

**Power Input:** 100 - 240 Volts input, 50-60Hz  
(international) input connector

**Power Output:** 75W produced @ 24VDC, 3.12 Amps

**Protocol Requirements:** USITT DMX512 (1990)

**Body Material:** High impact plastic

**Color:** Black

**Circuit Out Connectors:** One XLR 4-pin female  
(power and control protocol)

**Power Input Connector:** UL rated, supplied with detachable  
power cord IEC 10A

**Control Input Connector:** XLR 5-pin male

## ( Power Supply 200 Specifications )

**Dimensions:** 11.25" (H) x 6.75" (W) x 2.5" (D)  
285.75mm (H) x 171.45mm (W) x 63.5mm (D)

**Weight:** 3.8 lbs. / 1.72 kg.

**Power Input:** 82 - 260 Volt input, 50-60Hz  
(international) input connector

**Power Output:** 150W produced @ 24VDC 6.25 Amps

**Protocol Requirements:** USITT DMX512 (1990)

**Body Material:** Powder coat aluminium rear area,  
anodized aluminum front cover

**Mounting Options:** Table top or 1/2" hole provided for  
optional C-clamp for truss mounting.

**Color:** Black with white silk-screened legend

**Circuit Out Connectors:** Two XLR 4-pin female  
(power and control protocol)

**Return Connectors:** Two XLR 4-pin male  
(power and control protocol termination)

**Power Input Connector:** UL rated, supplied with detachable  
power cord IEC 10A

**Control Out Connector:** XLR 5-pin female (DMX link)

**Control Input Connector:** XLR 5-pin male  
(protected with clamping diodes)

## ( Calibration )

A self-calibration procedure will begin to set the 100% and 0% gel string settings. (It is advisable to have control protocol at the zero level to verify the gel string has been loaded properly).

**Note:** A high percentage of problems are caused by corrupt DMX control protocol. We highly recommend the use of genuine Apollo Design Technology cables for all Smart Color® scrollers and Smart Move® rotator units.

## ( Setting the DMX Address )

The Smart Color® uses **one of two channels** of DMX512 and can be addressed easily by setting the rotary switches located on the front panel. To set your desired DMX address, turn each rotary switch so that the address reads between 001 and 512. Then press the TEST button.

Because each DMX control console operates differently, consult the respective manufacturer's console manual for patching instructions. Please note that after patching the scroller into the console, the console's control channel number may (and probably will) be different than the scroller's DMX address number.

If you are controlling the scrollers with a console that has multiple DMX universes, please note that different consoles process multiple universes in varying ways. Each DMX universe consists of addresses between 001-512. In most conventional consoles, if a scroller with an address of 001 is connected to the second universe of the console, the console will view the scroller address as 513. In this example, 512 was added to the value of the scroller's address for the console to process it.

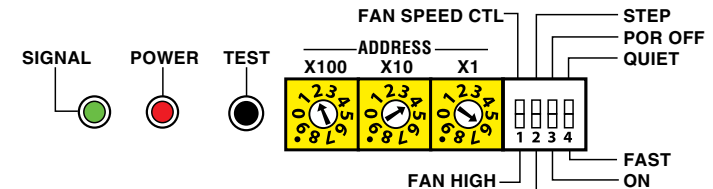

(Example DMX address 246 = 2 x100, 4 x10, 6 x1 as above)

## ( Fan Speeds )

**Fan Speed Control** is achieved by placing the #1 dip switch in the OFF (up) position.

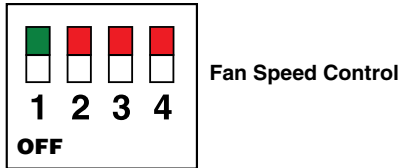

**High Fan Speed Control** is achieved by placing the #1 dip switch in the ON (down) position.

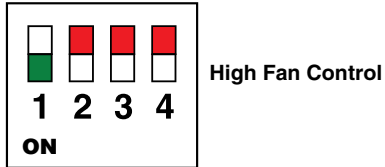

**Low Speed** set the address switches to 992 then press the test button. Set the address switches to the desired DMX address then press the test button.

**Medium Speed** set the address switches to 993 then press the test button. Set the address switches to the desired DMX address then press the test button.

**Remote Control from the Desk (individual channel control)**  
set the address switches to 994 then press the test button. Set the address switches to the desired DMX address then press the test button. The fan will respond to the DMX address +1.

**Fan Speed** The fan speed is continuously variable in response to the console fader. Fader position at 0% is fan at high speed. Fader position at 100% is fan stopped. Use extreme care when using this setting to avoid damage to the gel string.

**Remote Control from the Desk (grouped channel control)**  
set the address switches to 995 then press the test button. Set the address switches to the desired DMX address then press the test button. The fan will respond to the DMX address 512.

**Fan Speed** The fan speed is continuously variable in response to the console fader. Fader position at 0% is fan at high speed. Fader position at 100% is fan stopped. Use extreme care when using this setting to avoid damage to the gel string.

## ( Power Supply 400 Specifications )

**Dimensions:** 9.5" (H) x 10.75" (W) x 5.25" (D)  
241.3mm (H) x 273mm (W) x 133.4mm (D)

**Weight:** 7 lbs. / 3.18 kg.

**Power Input:** 115 or 230 Volt input, 50-60Hz  
(international) input connector

**Power Output:** 250W produced @ 24VDC, 10.4 Amps

**Protocol Requirements:** USITT DMX512 (1990)

**Body Material:** Powder coat aluminium rear area,  
anodized aluminum front cover

**Mounting Options:** Table top or 1/2" hole provided for  
optional C-clamp for truss mounting.

**Color:** Black with yellow silk-screened legend

**Circuit Out Connectors:** Two XLR 4-pin female  
(power and control protocol)

**Return Connectors:** Two XLR 4-pin male  
(power and control protocol termination)

**Power Input Connector:** UL rated, supplied with detachable  
power cord IEC 10A

**Control Out Connector:** XLR 5-pin female (DMX link)

**Control Input Connector:** XLR 5-pin male  
(protected with clamping diodes)

**( Power Supply 600 Specifications )**

- Dimensions:** 9.5" (H) x 10.75" (W) x 5.25" (D)  
241.3mm (H) x 273mm (W) x 133.4mm (D)
- Weight:** 10.5 lbs. / 4.76 kg.
- Power Input:** 115 or 230 Volt input, 50-60Hz  
(international) input connector
- Power Output:** 400W produced @ 24VDC, 16.6 Amps
- Protocol Requirements:** USITT DMX512 (1990)
- Body Material:** Powder coat aluminium rear area,  
anodized aluminum front cover
- Mounting Options:** Table top or 1/2" hole provided for  
optional C-clamp for truss mounting.
- Color:** Black with white silk-screened legend
- Circuit Out Connectors:** Two XLR 4-pin female  
(power and control protocol)
- Return Connectors:** Two XLR 4-pin male  
(power and control protocol termination)
- Power Input Connector:** UL rated, supplied with detachable  
power cord IEC 10A
- Control Out Connector:** XLR 5-pin female (DMX link)
- Control Input Connector:** XLR 5-pin male  
(protected with clamping diodes)

**( Auto Scrolling Mode )**

The Smart Color® can be used without a lighting control desk to scroll through each color frame at various pre-programmed speeds. Simply address the **first** rotary switch (X100) at **8** to bypass all incoming DMX signals if they are present.

*\*The second rotary switch (X10) sets the speed from the first frame to the last.*

*\*The third rotary switch (x1) sets the speed from the last frame to the first.*

Now press the TEST button to save this setting.

*\*\*The lower the number, the faster the scrolling speed.*

*(Example - When addressed at **891**, the scroller automatically scrolls slowly to the last frame, then quickly back to the first frame. When addressed at **819**, the scroller automatically scrolls quickly to the last frame, then slowly to the first frame.) Remember to press TEST after scrolling speed selection is made.*

The Smart Color® is designed to provide either smooth continuous scrolling, or frame by frame stepping when in the Auto Scrolling mode.

**Continuous operation** is achieved by setting DIP switch #2 in the ON (down) position.

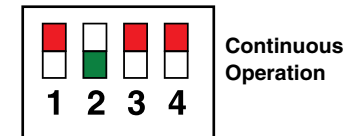

**Frame by frame stepping** is achieved by setting dip switch #2 in the OFF (up) position. Complete timing table is listed below.

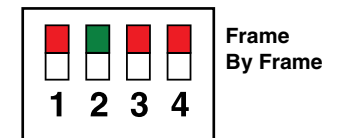

Auto scrolling speeds are equal for both continuous and stepping modes of operation. Speeds from first to last frames are as follows:  
**Rotary switch settings in bold type.**

<b>800</b> = 19 secs	<b>811</b> = 20 secs	<b>822</b> = 21 secs	<b>833</b> = 23 secs	<b>844</b> = 25 secs
<b>855</b> = 26 secs	<b>866</b> = 27 secs	<b>877</b> = 28 secs	<b>888</b> = 29 secs	<b>899</b> = 30 secs

## ( POR (Power on Reset) Option )

The **POR** option may be selected by setting DIP switch #3 in the **ON** (down) position.

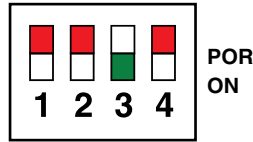

POR  
ON

Upon applying power, the gel string will scroll to the starting end (HEAD) of the string, back to the TAIL end, then to the HEAD again. If there is a control signal being sent from the console, the string will then advance to that selected frame position.

The **POR** option is turned **OFF** when DIP switch #3 is in the (up) position.

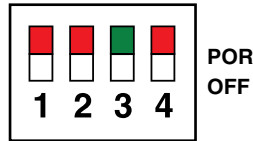

POR  
OFF

Upon applying power, the gel string will scroll to the starting end (HEAD) of the string. If there is a control signal being sent from the console, the string will then advance to that selected frame position.

## ( FAST Mode )

The general scrolling and calibration scrolling speed is controlled by DIP switch #4. When the DIP switch is in the **FAST** (down) position, the Smart Color® will calibrate from HEAD frame to TAIL frame in 2.0 seconds.

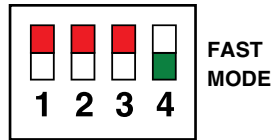

FAST  
MODE

The frame to frame scrolling speed will maximize at 2.0 seconds from HEAD to TAIL when this FAST selection is made.

## ( QUIET Mode )

General scrolling speed and calibration speed are slowed when DIP switch #4 is placed in the **QUIET** (up) position. The calibration time now becomes 8.0 seconds from HEAD frame to TAIL frame.

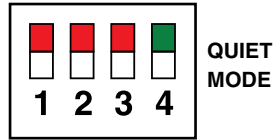

QUIET  
MODE

The frame to frame scrolling speed will maximize at 30 seconds from HEAD to TAIL frames when set in the QUIET position.

## ( Smart Color® 5.25 Specifications )

**Dimensions:** 9.63" (W) x 10.63" (H) x 2.63" (D)  
245mm (W) x 270mm (H) x 67mm (D)

**Aperture:** 5.12" / 130mm

**Weight:** 3.6 lbs. / 1.6 kg.

**Gel String Capability:** 16 frames

**High Speed:** 2 seconds head to tail

**Low Speed:** Variable to 30 seconds

**Address:** Rotary dipswitch address up to 512 channels

**DMX Channels Required:** One (two if using remote fan control)

**Power Requirements:** 24VDC

**Power Consumption:** 1.6 Amps at 24VDC Fan & Speed High  
.7 Amps at 24VDC Fan & Speed Low

**Protocol Requirements:** USITT DMX512 (1990)

**Body Material:** Aluminum plate

**Color:** Black powder coat

**Input Connector:** XLR 4-pin male  
(power and control protocol)

**Output Connector:** XLR 4-pin female  
(power and control protocol)

<b>Frames 1&amp;16</b>	16.87" (W) x 5.12" (H)	428mm (W) x 130mm (H)
<b>Frames 2-15</b>	9.45" (W) x 5.12" (H)	240mm (W) x 130mm (H)

**( Smart Color® 7.25 Specifications )**

**Dimensions:** 11.75" (W) x 13.50" (H) x 2.63" (D)  
298mm (W) x 343mm (H) x 67mm (D)

**Aperture:** 7.25" / 184mm

**Weight:** 4.6 lbs. / 2.1 kg.

**Gel String Capability:** 16 frames

**High Speed:** 2 seconds head to tail

**Low Speed:** Variable to 30 seconds

**Address:** Rotary dipswitch address up to 512 channels

**DMX Channels Required:** One (two if using remote fan control)

**Power Requirements:** 24VDC

**Power Consumption:** 1.6 Amps at 24VDC Fan & Speed High  
.7 Amps at 24VDC Fan & Speed Low

**Protocol Requirements:** USITT DMX512 (1990)

**Body Material:** Aluminum plate

**Color:** Black powder coat

**Input Connector:** XLR 4-pin male  
(power and control protocol)

**Output Connector:** XLR 4-pin female  
(power and control protocol)

<b>Frames 1&amp;16</b>	19.88" (W) x 7.75" (H)	505mm (W) x 197mm (H)
<b>Frames 2-15</b>	12.40" (W) x 7.75" (H)	315mm (W) x 197mm (H)

**( Gel String Movement Speed )**

The gel string scrolling speed can be set at any of 16 steps to compromise between speed and quietness. Set the Rotary Switches to **900** for fastest speed, and up to **915** for the slowest scrolling speed. After the address is entered, press the TEST button to program this speed into the Smart Color®.

You may now set the DMX address for the scroller by using the Rotary Switches and press TEST as detailed on page 6 of this manual.

**( Factory Default Settings )**

The Smart Color® scroller has been set to a factory default POWERSAVER setting. To set the scroller to factory default settings, simply set the Rotary Switches at 909 and press TEST. This will return the gel string movement to POWERSAVER mode.

LOW fan speed is the default of the Apollo Smart Color® scrollers for the quietest performance when Apollo Gel Shield is used for fixtures of less than 1000W.

To set the scroller to quicker factory default settings, simply set the Rotary Switches at 600 and press TEST. This will return the gel string movement speed to maximum speed.

Frame Position	DMX	%	Theatre String Color	Rock n' Roll String Color
1	0-15	3	Clear	Clear
2	16-31	9	Neon Yellow	Pilsner Yellow
3	32-47	15	Santa Fe Amber	Apollo Orange
4	48-63	21	Coral Amber	Golden Amber
5	64-79	28	Spiced Rum Amber	Diva Red
6	80-95	34	Apollo Orange	Bludgeon Red
7	96-111	41	Vixen Red	Hot Pink
8	112-127	47	Spanked Pink	Sour Grape
9	128-143	54	Hot Pink	Groovy Grape
10	144-159	60	Dominant Lavender	Voodoo Lavender
11	160-175	66	Groovy Grape	Heavenly Blue
12	176-191	72	Ice Blue	Apollo Blue
13	192-207	79	Heavily Blue	Bright Blue
14	208-223	85	After Hours Blue	Caribbean Blue
15	224-239	93	Margarita Green	Neptune Blue Green
16	240-256	100	Neptune Blue Green	Rock 'n Roll Green

## ( Mounting Position )

The Smart Color® is designed to work in an upright position with the base of the unit below the lighting fixture. Avoid mounting in an inverted position with the base of the unit above the fixture, or sideways, as the rising heat from the fixture may cause gel string damage.

Always make sure the Smart Color® is powered up before the lighting fixture and that you follow the reverse procedure at the end of the show. Lamp heat is torturous to gel strings, especially when the scroller fan is 'OFF'. Failure to do so may cause gel string damage. Apollo Gel Shield offers some degree of protection from gel string failure if this procedure is ignored or forgotten.

Always ensure that the safety cable attached to the Smart Color® is attached to the yoke of the lighting fixture or pipe and clipped securely. Apollo Design Technology, Inc is not responsible for damage or injury resulting from the misuse of this product, or negligence on behalf of the user.

**Note:** Lubrication of bearings is NOT required or recommended. The precision roller bearings are permanently lubricated.

## ( Universal Mounting Plate System )

The Smart Color® is provided with a standard mounting plate, with an optional upgrade to the Apollo Universal Mounting Plate System.

The Universal Mounting Plate System incorporates three labeled positions, allowing the user to prepare the scroller for use with lighting fixtures from 6.25 to 10 inches.

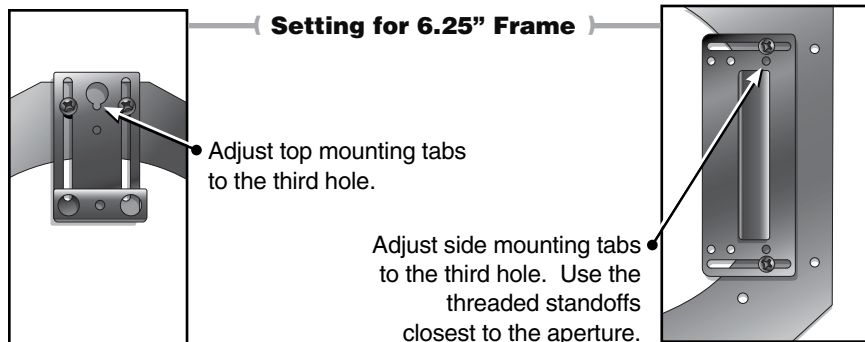

## ( Specifications )

### ( Smart Color® 10.0 Specifications )

**Dimensions:** 14.50" (W) x 16.25" (H) x 2.63" (D)  
368mm (W) x 413mm (H) x 67mm (D)

**Aperture:** 10" / 254mm

**Weight:** 5.6 lbs. / 2.5 kg.

**Gel String Capability:** 11 frames

**High Speed:** 2 seconds head to tail

**Low Speed:** Variable to 30 seconds

**Address:** Rotary dip switch address up to 512 channels

**DMX Channels Required:** One (two if using remote fan control)

**Power Requirements:** 24VDC

**Power Consumption:** 1.6 Amps at 24VDC Fan & Speed High  
.7 Amps at 24VDC Fan & Speed Low

**Protocol Requirements:** USITT DMX512 (1990)

**Body Material:** Aluminum plate

**Color:** Black powder coat

**Input Connector:** XLR 4-pin male  
(power and control protocol)

**Output Connector:** XLR 4-pin female  
(power and control protocol)

**LED Indicators:** Red - power signal;  
Green - DMX / Warning Signal

<b>Frames 1&amp;11</b>	22.64" (W) x 10.5" (H)	575mm (W) x 267mm (H)
<b>Frames 2-10</b>	15.16" (W) x 10.5" (H)	385mm (W) x 267mm (H)

Larger aperture of the Smart Color® 10.0 limits the frame selection to 11 color frames. Call Apollo for a list of the stock gel colors available.

## ( Cleaning )

The Smart Color® scroller uses an optical encoding method to calculate the position of the gel filter. If dust, smoke, fog juice, or other debris accumulates on the optical devices, the position accuracy of the gel string will begin to shift.

To properly clean the optical encoding sensors:

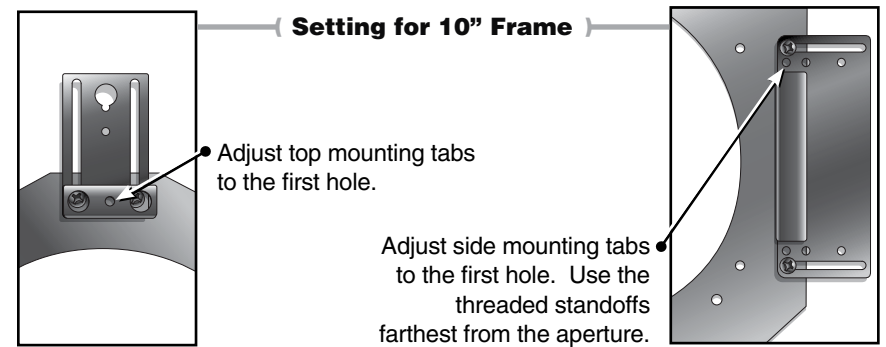
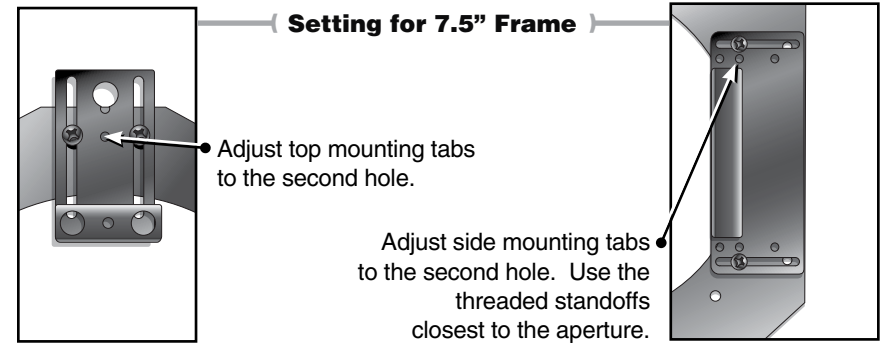
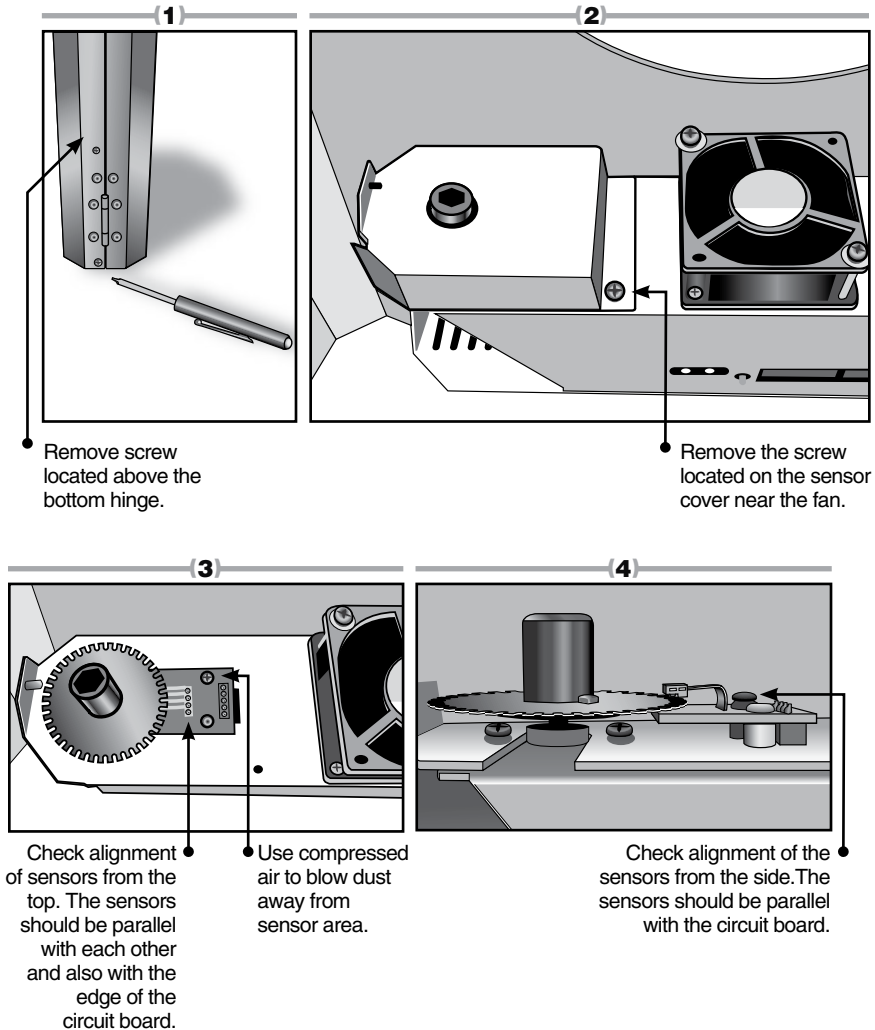

## ( Gel String Dimensions )

The standard gel string consists of a head, the gel frames, and a tail. Apollo Gel is recommended, but other gel brands are acceptable. Stock gel strings are made exclusively with quality Apollo Gel.

**Note:** The gel frames are longer at the head and tail. (Frames 1 & 16)  
 The gel frames are shorter between the head and tail. (Frames 2-15)  
 The gel string is positioned against the scribed line and then taped directly on the roller tubes with high-temp polyester tape.

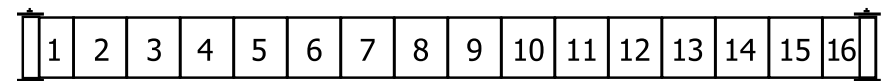

Frame dimensions for each model can be found on pages 16-18.

## ( Gel String Assembly )

Clear high-temperature polyester tape, also available from Apollo, is recommended for gel string production. Carefully cut the desired frames of the chosen gel, or use Apollo's PerfGel that is perforated for precision fit. Note that the two end frames (Head and Tail) are longer than the rest of the gel frames. Tape all gel frames together on one side. Use a straight edge as your guide to help maintain wrinkle-free operation.

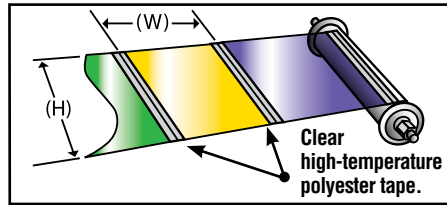

## ( Loading Gel Strings )

The Smart Color® scroller is shipped with the gel string installed at Apollo Design Technology, Inc. Should you desire to make your own custom gel string, installation is quick and easy.

To load the gel string into the scroller, stand the scroller on a flat surface facing you. **BE SURE THE POWER IS DISCONNECTED.**

- 1) Release the latch to open the front cover. Loosen the two thumbscrews on top for the right side (TAIL) roller. Carefully lift the bearing assembly up to allow the removal of the gel roller. This is a precision fit, use patience and care.
- 2) Repeat the procedure for the left side (HEAD) roller.
- 3) Roll the complete gel string onto this roller and repeat the taping process for the TAIL roller side, using the scribed line as your guide.
- 4) Insert HEAD roller into bottom bearing first, then insert roller top into the upper bearing assembly. Use care, this is a precision fit.
  - \* Be sure gel string is positioned between the front cover and the cooling fan. This ensures airflow between lighting fixture and the gel string.

- 5) Tighten the four thumbscrews on the upper bearings with your fingers - use no tools, pliers, hammers, vice-grips, etc.
- 6) Remove excess slack from gel string by holding either roller and gently turning the other roller in the opposite direction. Close door and securely latch. Apply power and ensure the gel string is positioned between the front cover and the cooling fan for proper ventilation.

## ( Apollo Gel Shield )

When the Smart Color® is used on lighting fixtures of 750W or more, we strongly recommend the use of Apollo Gel Shield placed under the mounting plate in order to protect the gel string from excessive heat. Apollo Gel Shield has a coated side that is marked with a label. This labelled side should be placed toward the lamp of the fixture. Your Smart Color® was delivered with this Apollo Gel Shield installed. If this Gel Shield is missing, please consult either the selling dealer or Apollo Design Technology, Inc directly.

The Apollo Gel Shield allows the Smart Color® scrollers to operate with fan speeds on LOW for quieter operation. Use HIGH fan speed when Apollo Gel Shield is not being used, or for fixtures over 1000W.